

MATERIAL SALES
7.99SF

ALBANY YARD
6.56SF

62.82 S.F.
EXISTING BUILDING

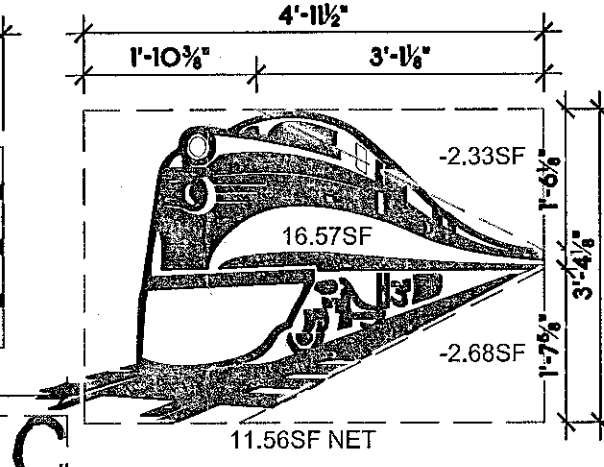
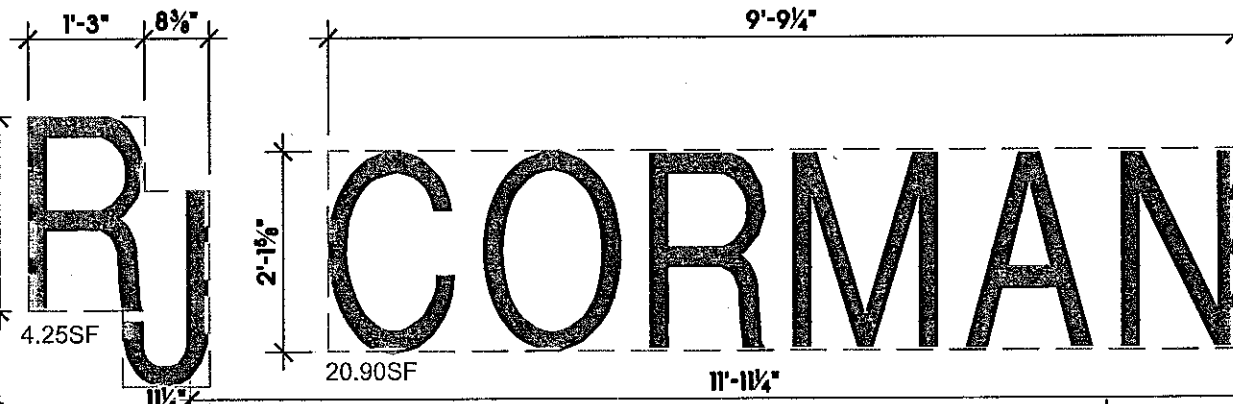
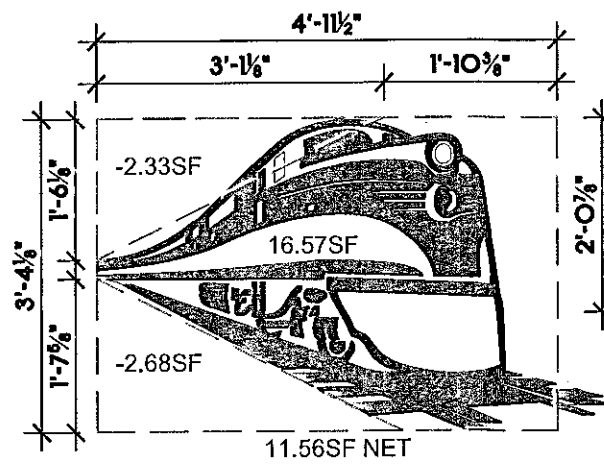

DERAILMENT SERVICES, LLC.
11.49SF

ALBANY YARD
6.56SF

66.32 S.F.
PROPOSED NEW BUILDING

129.14 S.F. TOTAL FOR TWO SIGNS

BUILDING SIGNAGE
SCALE: 1/2" = 1'-0"

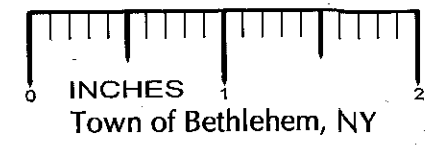

PLANNING BOARD
TOWN OF BETHLEHEM
ALBANY COUNTY, NEW YORK

This Site Plan Approved.
George J. J...
Title Chairman
SP/ISS

Date 8/8/12

ARCHITECT
BRIAN D. SAWYER, AIA
ARCHITECT
(859) 266-3594
www.bdsarc.com

OWNER / APPLICANT
R.J. CORMAN MATERIAL SALES
101 R.J. CORMAN DRIVE
NICHOLASVILLE, KENTUCKY 40356
(859) 881-2465 (phone)

APPLICATION FOR SITE PLAN REVIEW
R.J. CORMAN RAILROAD
BUILDING EXPANSION
19 SPEEDER ROAD
TOWN OF BETHLEHEM, ALBANY
COUNTY, NEW YORK

DATE: 06.11.12

A-3