

GENERAL NOTES

PLANNING BOARD  
TOWN OF BETHELHEM  
ALBANY COUNTY, NEW YORK  
FINAL PLAT APPROVAL  
WHEN SIGNED BY THE QUALIFIED  
OFFICER OF THE PLANNING BOARD, THIS  
ENGINEERING CONSTITUTES FINAL APPROVAL  
OF THIS PLAT.  
SIGNED: *Robert J. Math*  
TITLE: *Charlelew*  
DATE: *10/17/2016*  
SEE ALSO CERTIFICATE OF APPROVAL  
OF FINAL PLAT NO. *16466-01*

UNAUTHORIZED ALTERATIONS OR ADDITIONS TO THIS DOCUMENT  
IS A VIOLATION OF THE PROFESSIONAL ENGINEERING LAW OF THE  
STATE OF NEW YORK.

REVISIONS

DATE	BY	DESCRIPTION	SYMBOL
6/29	DNJ	FINAL PLAN REVISIONS	▲
10/29	DNJ	FINAL PLAN REVISIONS	▲
5/20	DNJ	FINAL PLAN REVISIONS	▲
12/20	DNJ	FINAL PLAN REVISIONS	▲
11/24	DNJ	FINAL PLAN REVISIONS	▲
10/24	DNJ	FINAL PLAN REVISIONS	▲
1/28	DNJ	FINAL PLAN REVISIONS	▲
7/08	DNJ	FINAL PLAN REVISIONS	▲
3/08	DNJ	FINAL PLAN REVISIONS	▲

**EDWARD W. BOUTELLE  
AND SON**  
CIVIL ENGINEERS AND SURVEYORS  
423 KENWOOD AVENUE  
DELMAR, NEW YORK  
TEL (516) 439-9981 FAX (516) 439-9982  
A DIVISION OF J. EDWARDS PRASER AND ASSOCIATES, P.C., ILL. P.C.

FINAL PLAN  
AMENDED  
**CARRIAGE HILL  
SUBDIVISION**  
MAP OF LANDS OF  
**CHARLEW  
CONSTRUCTION CORP.**

SEP 15 2016  
TOWN OF BETHELHEM, ALBANY COUNTY OF NEW YORK  
SCALE: AS NOTED

PROJ. SURVEYOR: CHJ  
DRAWN BY: TWK  
ASSEMBLED BY: TWK  
CHECKED BY: CHJ  
PROJECT NO.: 99-020  
CAD FILE NAME: 4103-021

SHEET TITLE: **PLAN & PROFILE  
DRAINAGE EASEMENTS "E", "G", "H", AND "I"**  
DATE: NOVEMBER 1995 SHEET 21 OF 31

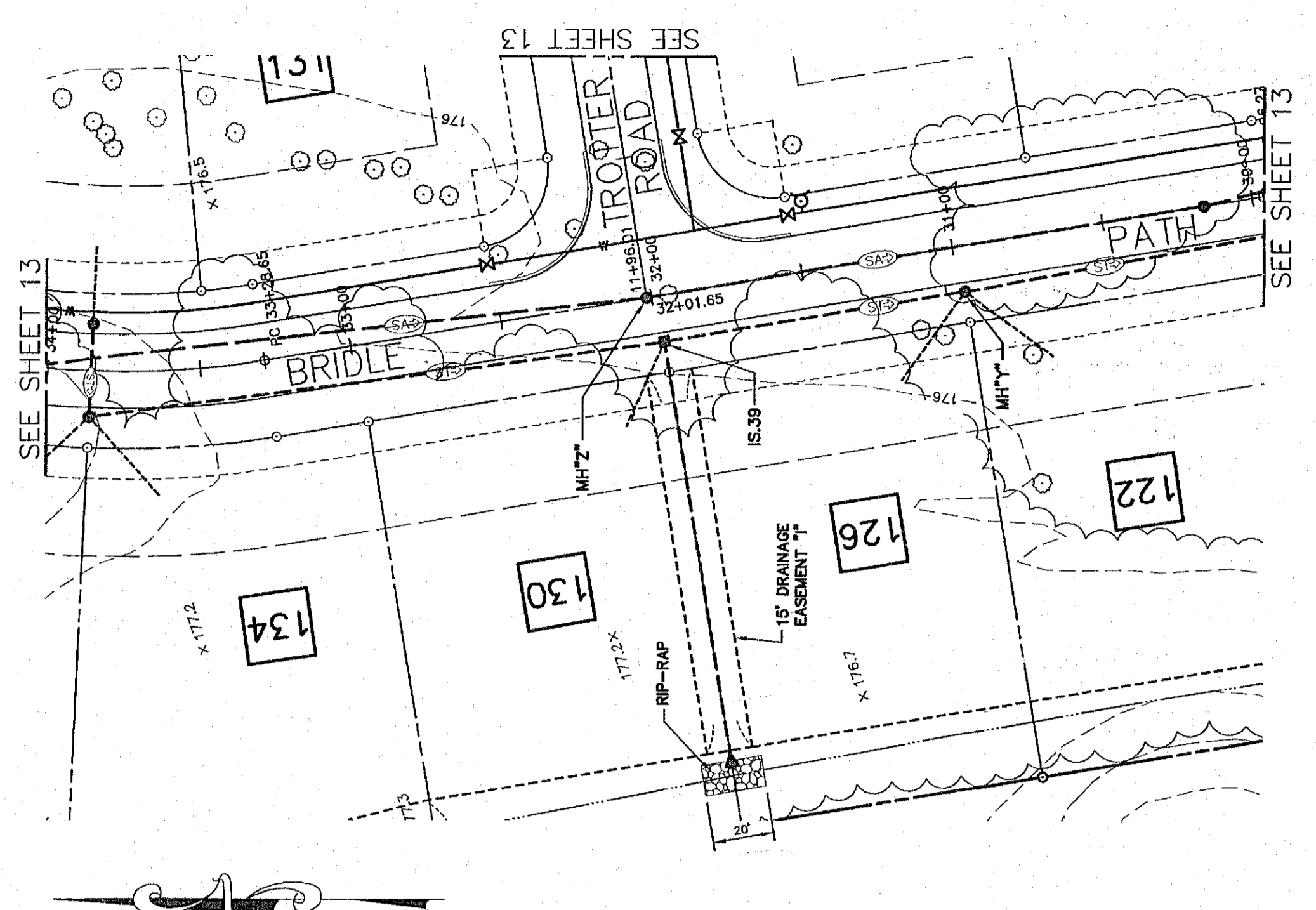

**GENERAL PLAN - DRAINAGE EASEMENT "I"**  
SCALE: 1"=40'

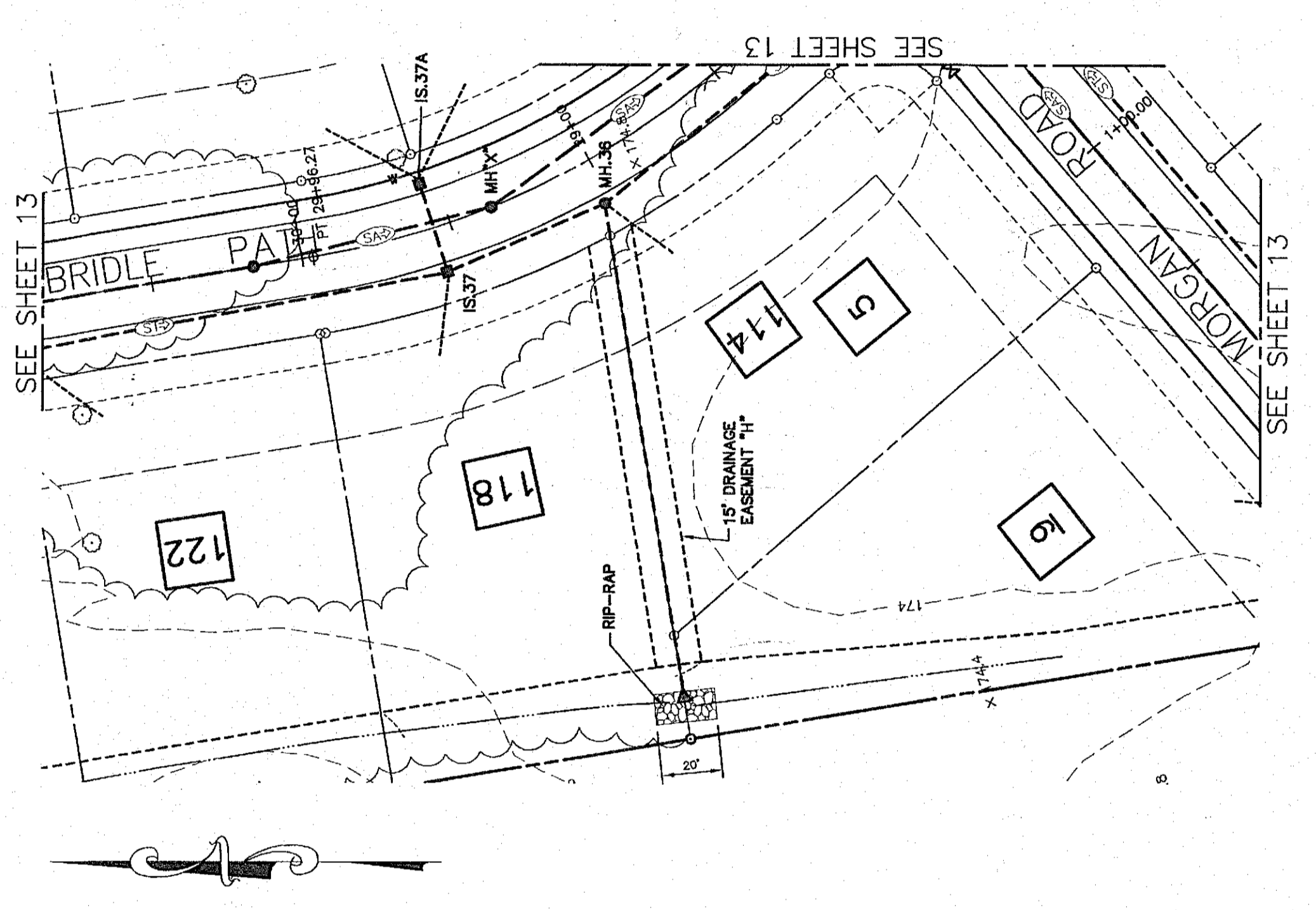

**GENERAL PLAN - DRAINAGE EASEMENT "H"**  
SCALE: 1"=40'

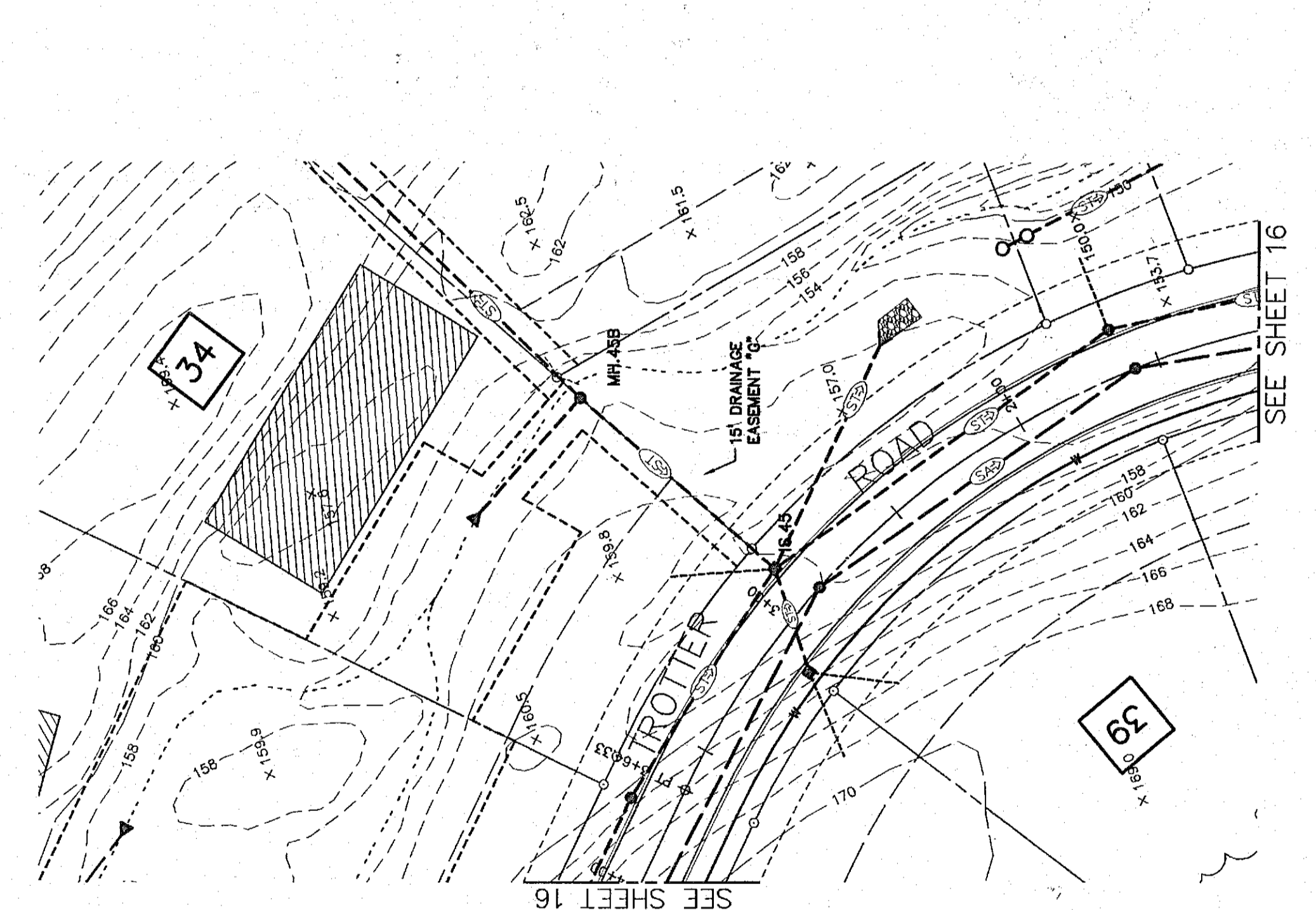

**GENERAL PLAN - DRAINAGE EASEMENT "G"**  
SCALE: 1"=40'

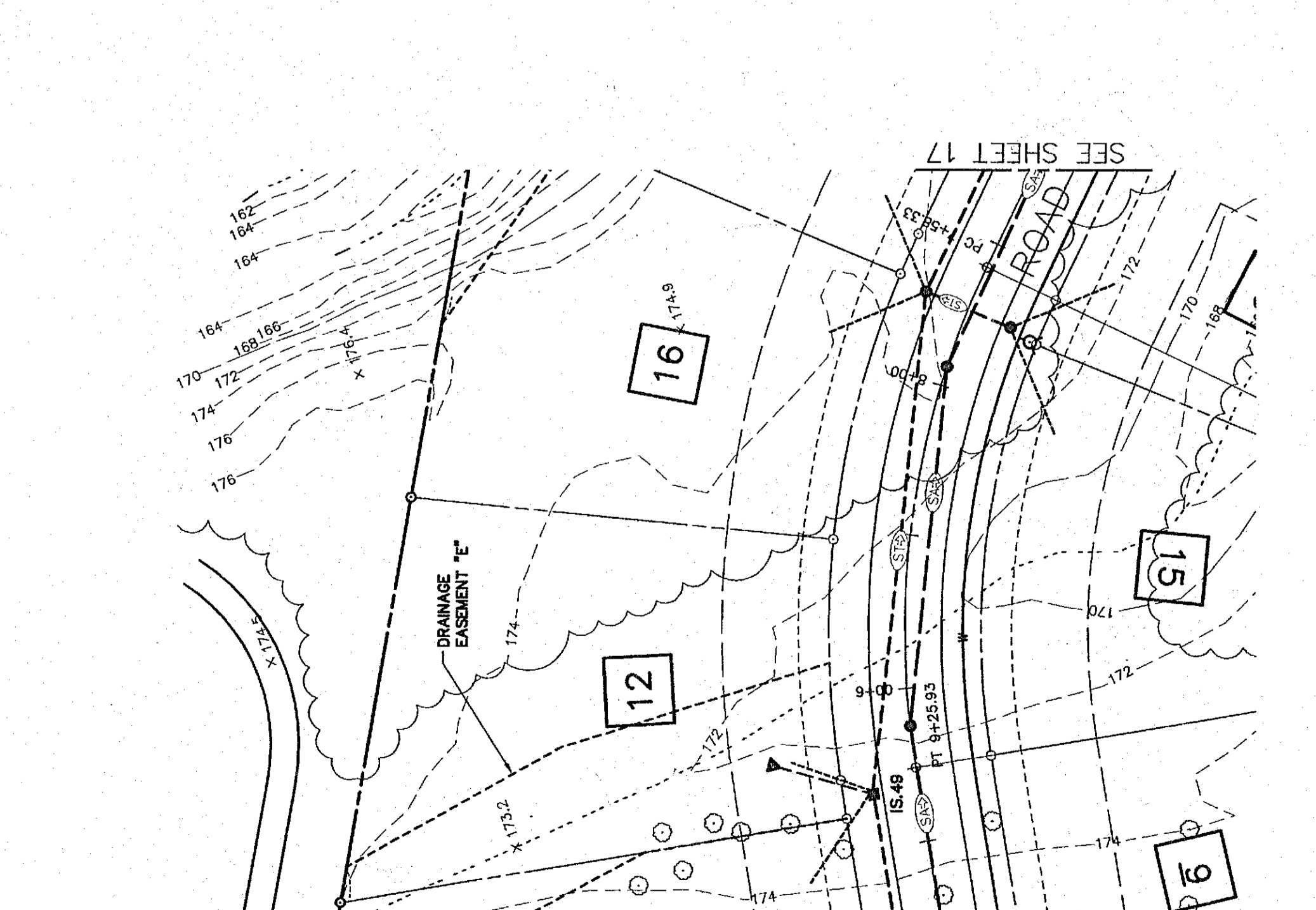

**GENERAL PLAN - DRAINAGE EASEMENTS "E"**  
SCALE: 1"=40'

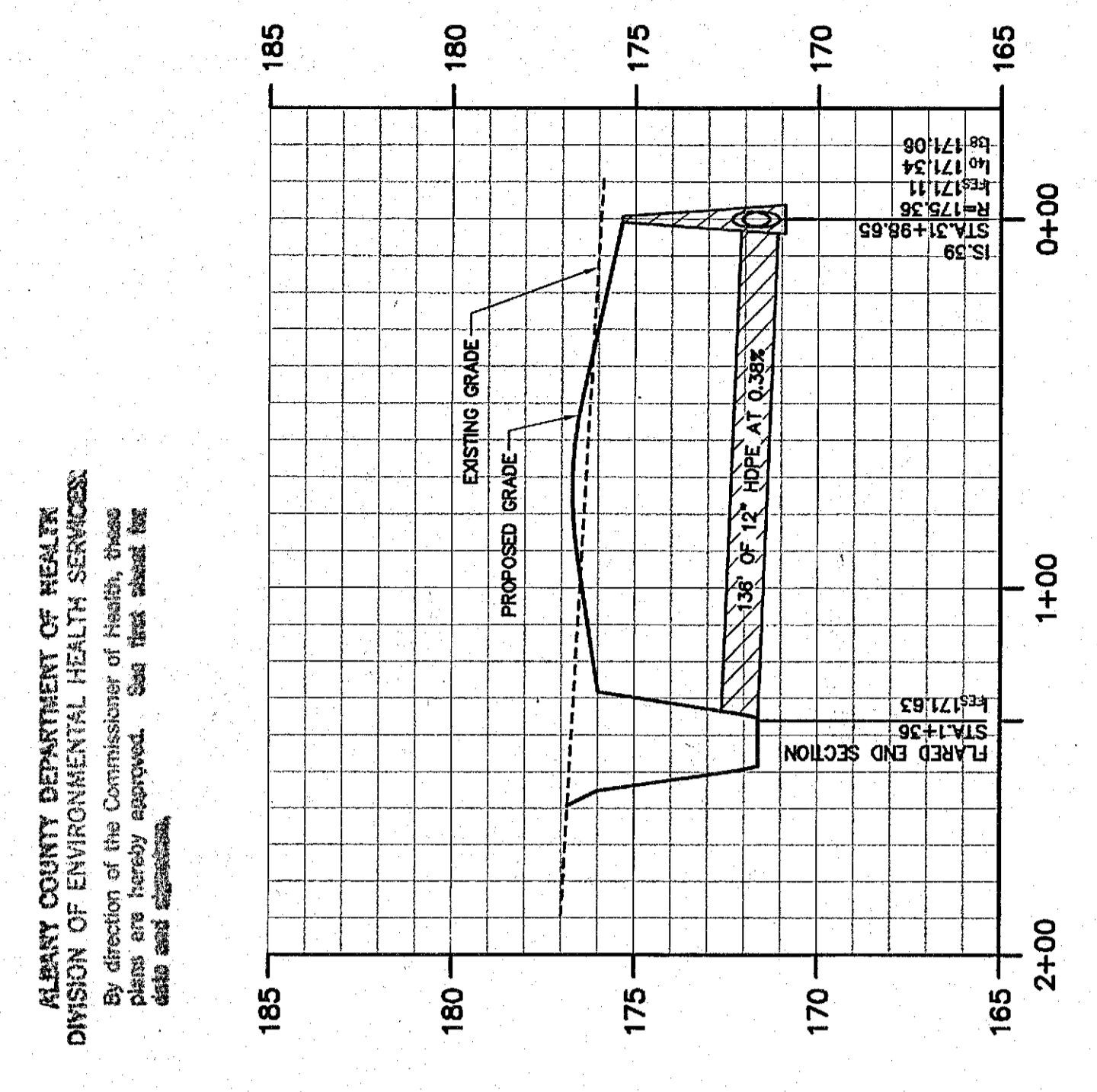

**PROFILE - EASEMENT "I"**  
SCALE: 1"=4' VERT. / 1"=40' HORIZ.

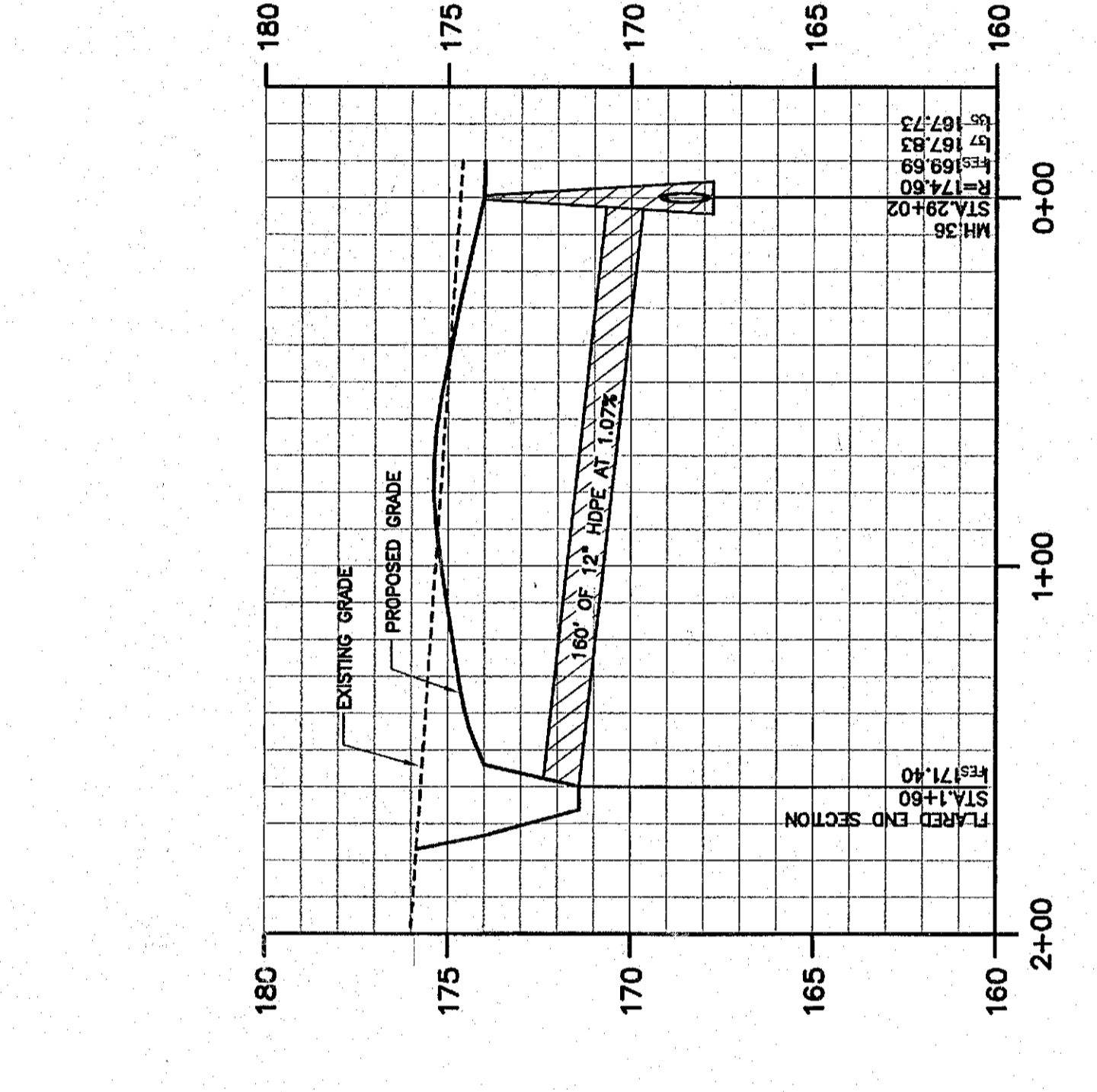

**PROFILE - EASEMENT "H"**  
SCALE: 1"=4' VERT. / 1"=40' HORIZ.

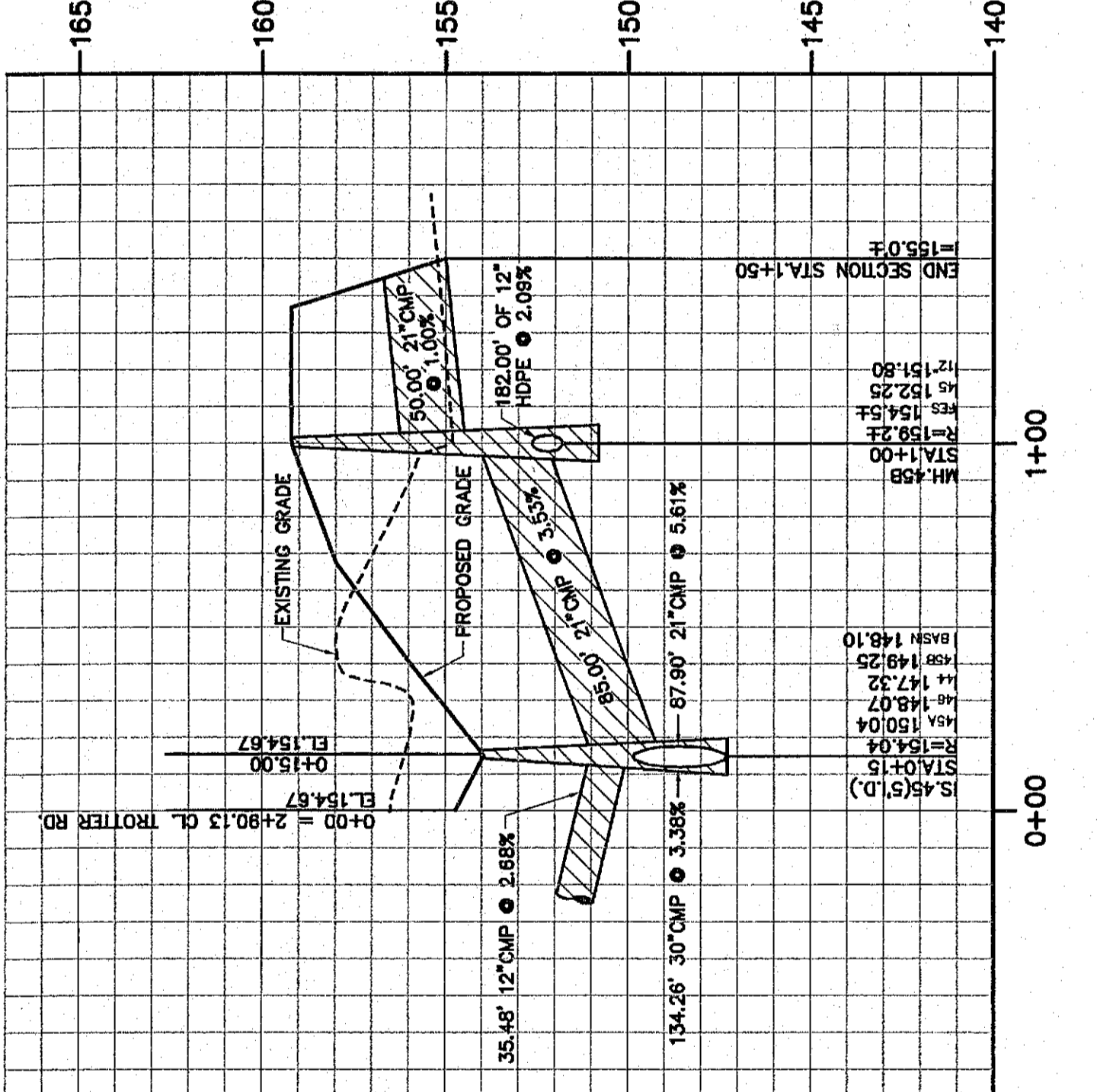

**PROFILE - EASEMENT "G"**  
SCALE: 1"=4' VERT. / 1"=40' HORIZ.

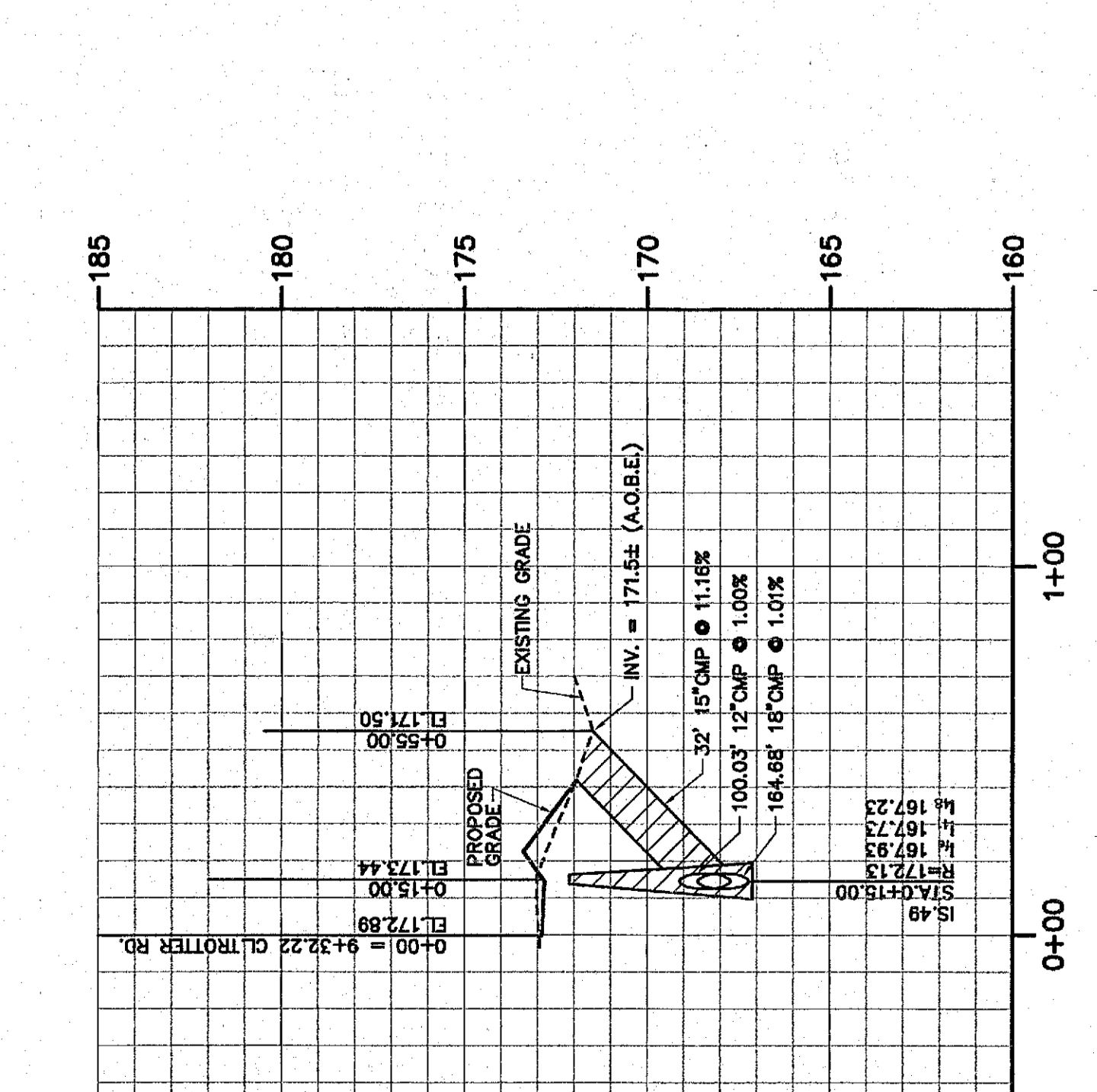

**PROFILE - EASEMENT "E"**  
SCALE: 1"=4' VERT. / 1"=40' HORIZ.

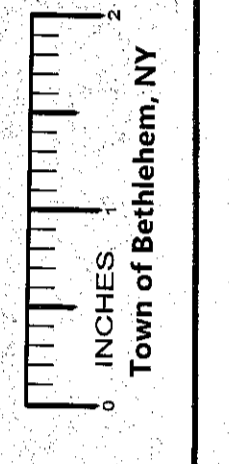

Town of Bethlehem, NY

